

# ASSEMBLY INSTRUCTIONS

**MODEL: 2182**

**SET TABLE**



2182SET-WH16Y

Before you begin, please follow Assembly Instructions carefully. Then follow them step by step.

## PART LIST

A	TABLE TOP	1 PCS
B	TABLE LEGS	4 PCS

## HARDWARE LIST

C	BOLT SCREW		8 PCS
D	SPRING WASHER		8 PCS
E	FLAT WASHER		8 PCS

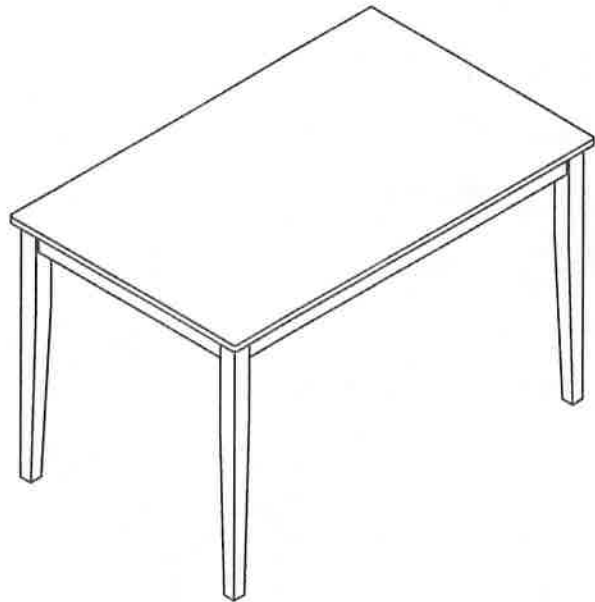

**Important note:** Place all wooden parts on a clean and smooth surface such as a rug or carpet to avoid the parts from being scratched. Affix the table legs (B) to the corner block with hex crew (C) spring washer (D). And flat washer (E). Then tighten the hex screw (C) by using the allen key (F).

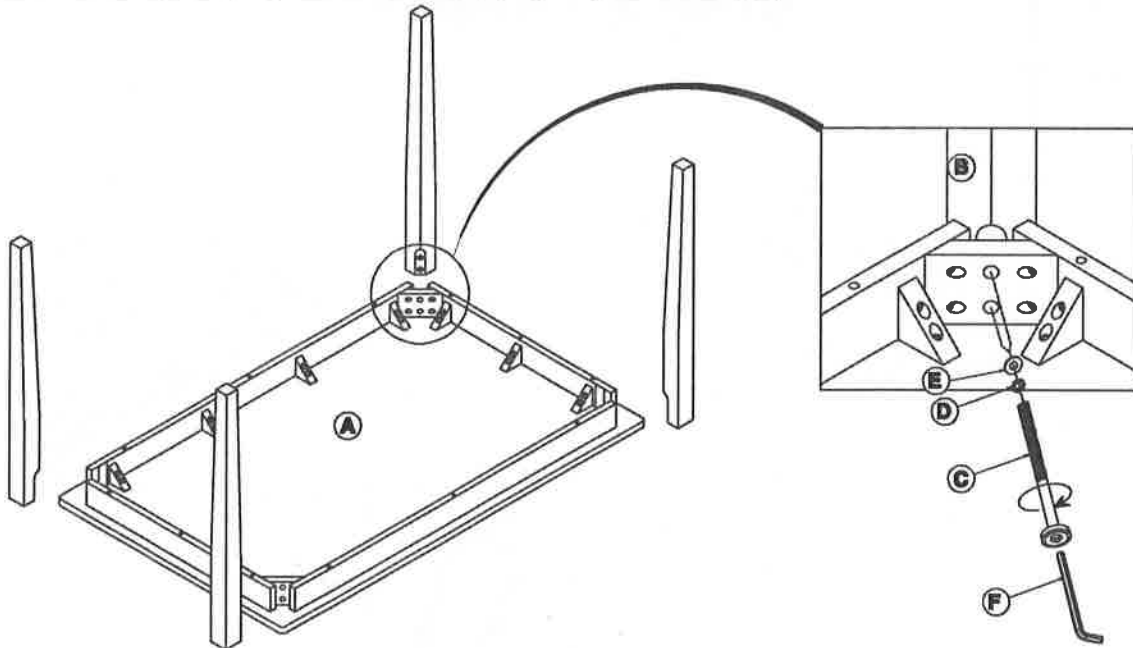

# ASSEMBLY INSTRUCTIONS

MODEL: 2182

CHAIR

2182 SET-WH/GY

**IMPORTANT NOTE:**

- PLACE ALL WOOD PARTS ON A CLEAN AND SMOOTH SURFACE SUCH AS A CARPET TO AVOID THE PARTS FROM BEING SCRATCHED
- BEFORE YOU BEGIN, READ ALL THE INSTRUCTIONS AND MAKE SURE THAT YOU HAVE ALL THE PARTS NEEDED.
- DO NOT FULLY TIGHTEN ALL SCREW UNTILL THE CHAIR IS FULLY SET UP. AFTER THE STEPS ARE COMPLETED FULLY TIGHTEN ALL SCREW AND CHECK TO MAKE SURE THE CHAIR IS LEVEL BEFORE USING.

**HARDWARE LIST**

A	BOLT Ø12*14**3"		4 PCS
B	BOLT Ø12*14**2"		4 PCS
C	BOLT Ø12*14**1-3/8"		1 PC
D	SPRING WASHER		9 PCS
E	FLAT WASHER		9 PCS
F	ALLEN KEY 4MM		1 PC

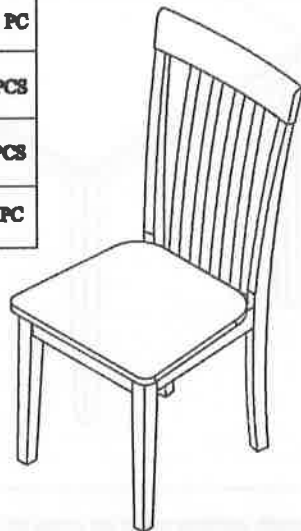

**STEP: 1**

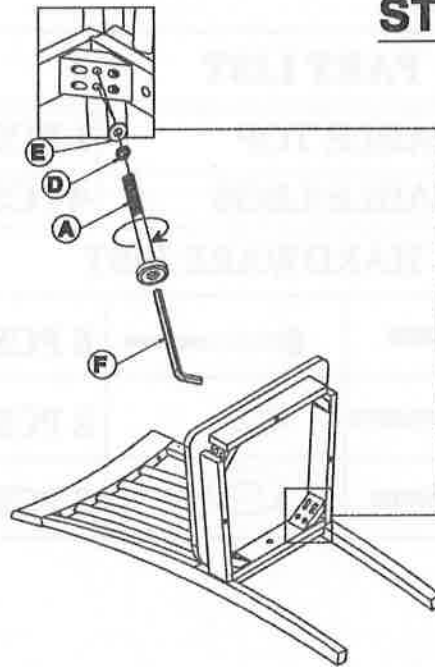

**STEP: 2**

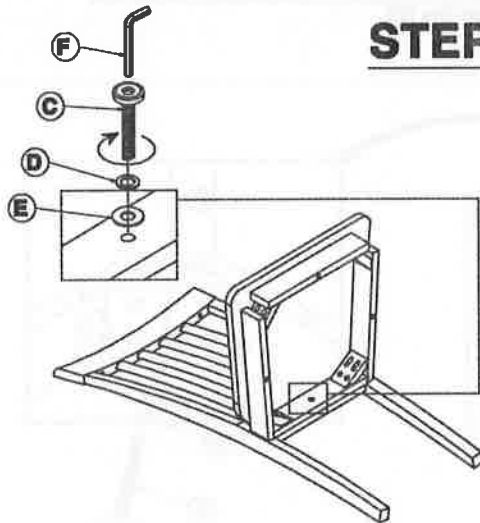

**STEP: 3**

