



LIVING SPACES

ASSEMBLY INSTRUCTION

AMOS EXTENSION TABLE :180/230x105x76 cm

LS SKU # 85249



CAUTION: PLEASE READ ALL INSTRUCTIONS BEFORE STARTING THE ASSEMBLY OF THIS PRODUCT. THESE PIECES ARE HEAVY. IN ORDER TO PREVENT PERSONAL INJURY AND ENSURE THAT THIS PRODUCT IS NOT DAMAGED DURING THE ASSEMBLY PROCESS, IT IS STRONGLY RECOMMENDED THAT YOU ENLIST THE ASSISTANCE OF ONE OR MORE PEOPLE.

ATTENTION: VEUILLEZ LIRE, TOUTES LES INSTRUCTIONS AVANT DE COMMENCER L'ASSEMBLAGE DE CE PRODUIT. LES PIECES SONT LOURDES. POUR EVITER TOUTE BLESSURE ET POUR VOUS ASSURER QUE LE PRODUIT N'EST PAS ENDOMMAGE' PENDANT L'ASSEMBLAGE, NOUS VOUS RECOMMANDONS DE FAIRE APPEL A UNE OU PLUSIEURS AUTRES PERSONNES.

CUIDADO: FAVOR DE LEER TODES LAS INSTRUCCIONES ANTES DE ENSAMBLAR SU PRODUCTO. ESTAS PIEZAS SON PESADAS. PARA PREVENIR HERIDAS PERSONALES Y ASEGURAR QUE SU PRODUCTO NO SEA DAN ADO MIENTRAS ES ENSAMBLADO, SE RECOMIENDA LA ASISTENCIA DE UNA O MAUS PERSONAS.

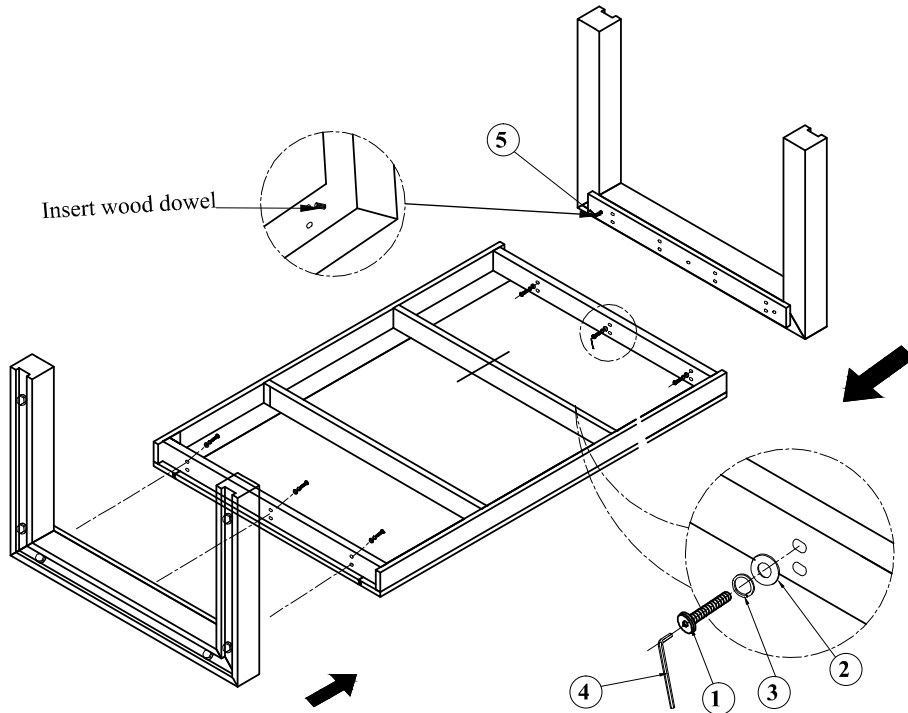

LIST OF PARTS AND HARDWARE			
No.		Description	Q'ty
A		TOP	1
B		LEG	2
C		SHORT SIDE TOP	1

LIST OF PARTS AND HARDWARE				
Q'ty		Description		No.
1		Bolts	M8 x 60	16
2		Washers	M8 x 22	16
3		Lock Washers	M8 x 13	16
4		Allen key	K4	1
5		Wood dowel	10 x 30	6



LIVING SPACES

ASSEMBLY INSTRUCTION

AMOS EXTENSION TABLE : 180/230x105x76 cm
LS SKU # 85249

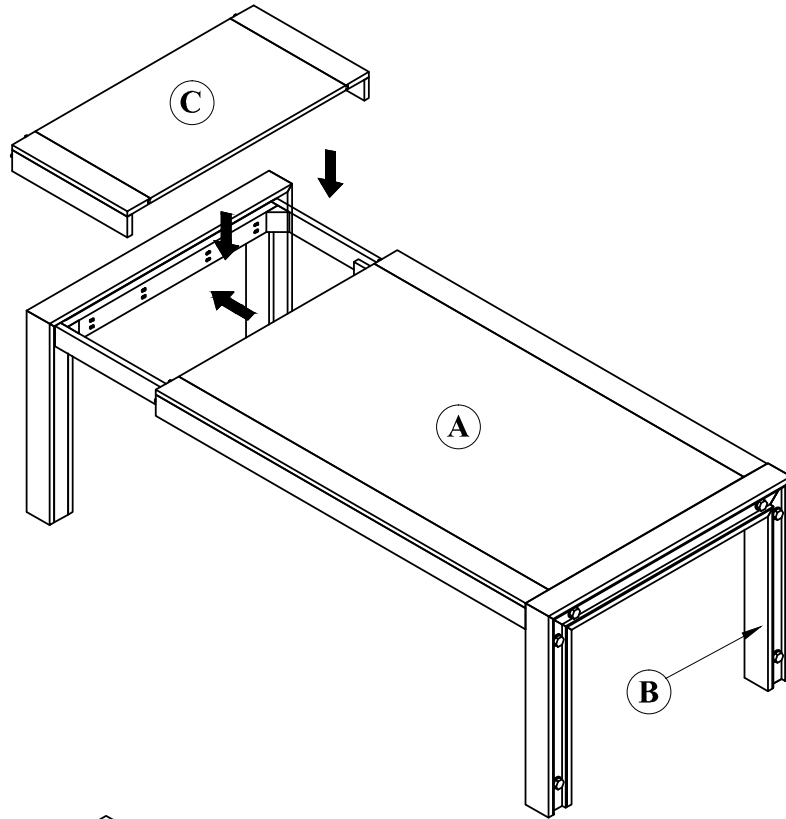

Finish

