

ASSEMBLY INSTRUCTIONS

ITEM NO : B8280 - 7
TACOMA TV STAND

BOX FOR TACOMA ENTERTAINMENT

| ITEM | DRAWING | DESCRIPTION | QTY |
|------|---------|--------------|-----|
| A | | TOP PANEL A | 1 |
| B | | TOP PANEL B | 1 |
| C | | SIDE PANEL | 2 |
| D | | CENTER PANEL | 1 |
| E | | SHELF | 2 |
| F | | BACK PANEL | 1 |
| G | | SUPPORT LEG | 1 |
| H | | SIDE FRAME L | 1 |
| I | | SIDE FRAME R | 1 |

HARDWARE LIST

| ITEM | DRAWING | DESCRIPTION | QTY |
|------|---------|--|-----|
| 1 | | ALLEN WRENCH (M4) | 1 |
| 2 | | CAM BOLT (T24) | 6 |
| 3 | | CAM NUT (D15 X 9.5mm) | 6 |
| 4 | | SMALL WOOD DOWEL (M6 x 40mm) | 12 |
| 5 | | BIG WOOD DOWEL (M8 x 30mm) | 4 |
| 6 | | CONNECTION BOLT (M6 x 60mm) W/WASHER & SPRING WASHER | 4 |
| 7 | | CONNECTION BOLT (M6 x 80mm) W/WASHER & SPRING WASHER | 12 |
| 8 | | BARREL NUT (M6 x 13mm) | 4 |
| 9 | | METAL SHELF NUT WITH HOLE (G165) | 8 |
| 10 | | Assembly Tool Not Included | 1 |

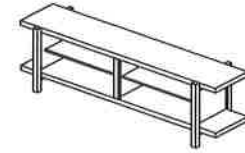

**COMPLETED
TACOMA TV STAND
ASSEMBLY**

STEP 1

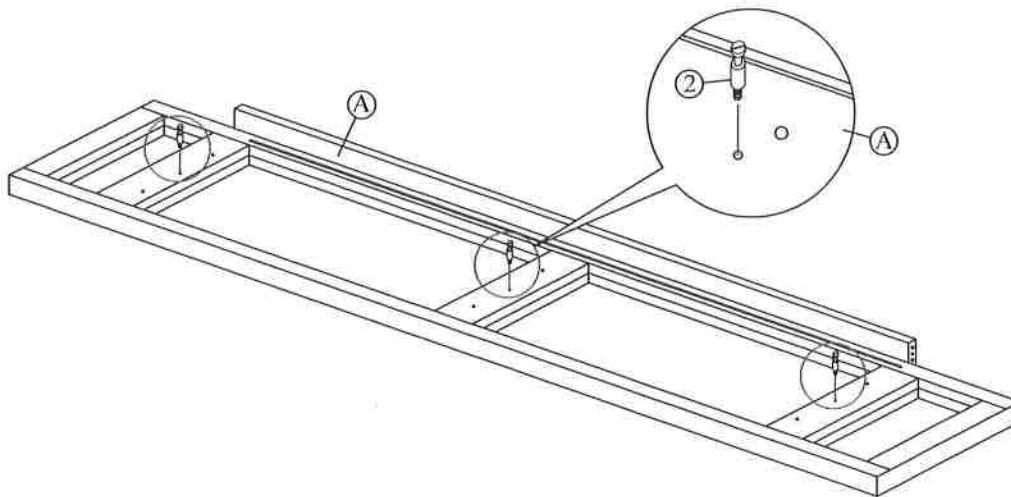

THE HARDWARE IS LOCATED IN THE PACKING ITEMS

NOTE : MUST TIGHTEN SCREWS PERIODICALLY. WITH USE SCREW MAY BECOME LOOSE.
CHECK TIGHNESS OF ALL SCREW EVERY 6-8 WEEKS.

CLEANING INSTRUCTION

After assembly, clean & polish the completed parts if necessary with soft cloth and industrial recognized furniture polish

ASSEMBLY INSTRUCTIONS

ITEM NO : B8280 - 7
TACOMA TV STAND

STEP 2

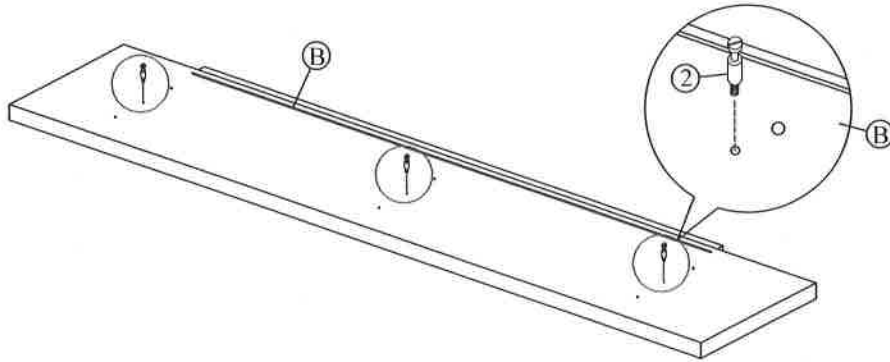

STEP 3

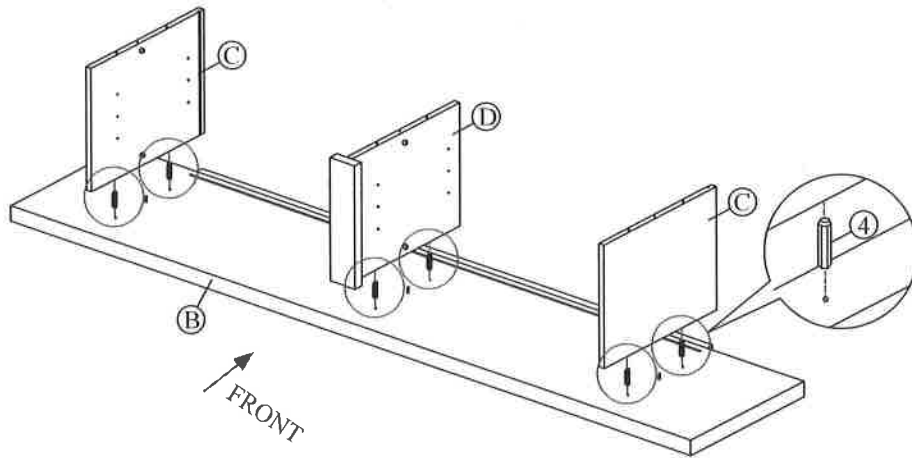

STEP 4

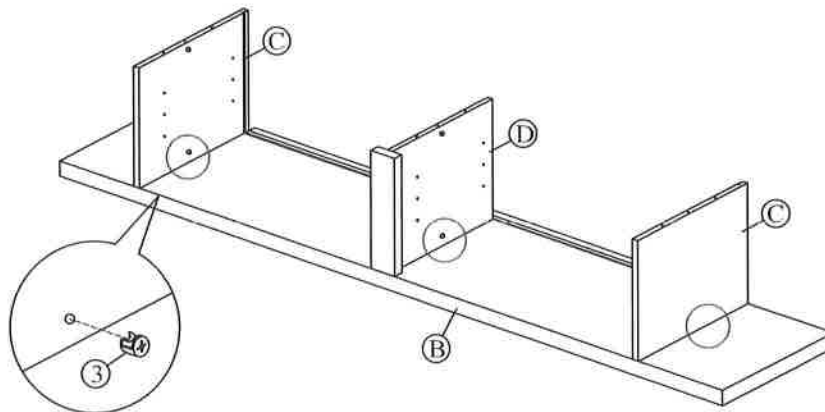

THE HARDWARE IS LOCATED IN THE PACKING ITEMS

NOTE : MUST TIGHTEN SCREWS PERIODICALLY. WITH USE SCREW MAY BECOME LOOSE.
CHECK TIGHTNESS OF ALL SCREW EVERY 6-8 WEEKS.

CLEANING INSTRUCTION

After assembly, clean & polish the completed parts if necessary with soft cloth and industrial recognized furniture polish

MADE IN MALAYSIA

ASSEMBLY INSTRUCTIONS

ITEM NO : B8280 - 7
TACOMA TV STAND

STEP 5

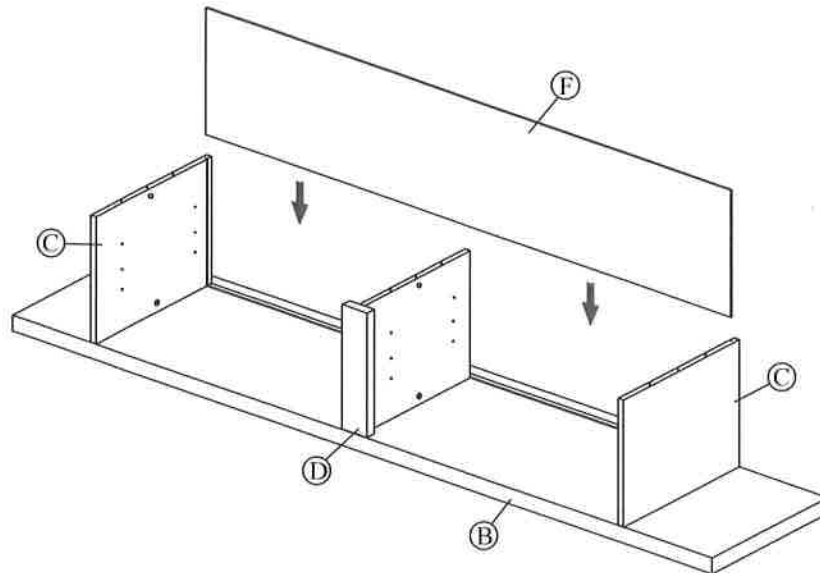

STEP 6

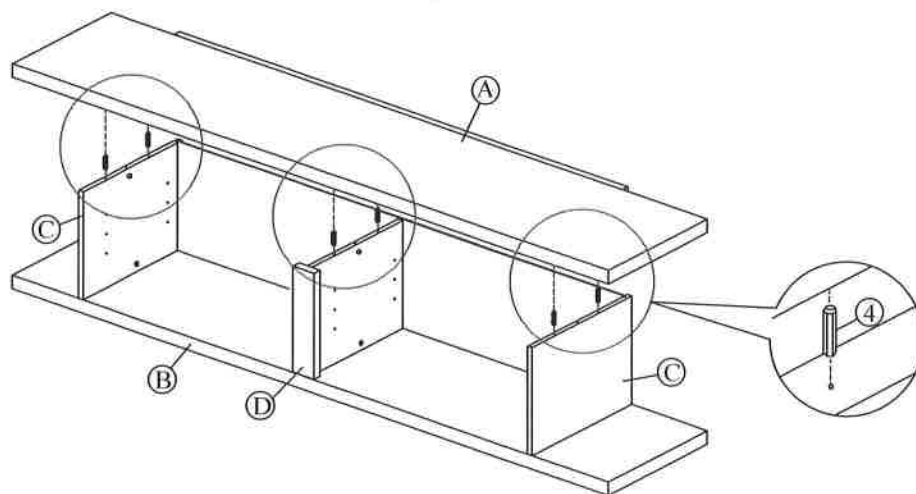

THE HARDWARE IS LOCATED IN THE PACKING ITEMS

NOTE : MUST TIGHTEN SCREWS PERIODICALLY. WITH USE SCREW MAY BECOME LOOSE.
CHECK TIGHTNESS OF ALL SCREW EVERY 6-8 WEEKS.

CLEANING INSTRUCTION

After assembly, clean & polish the completed parts if necessary with soft cloth and industrial recognized furniture polish

MADE IN MALAYSIA

ASSEMBLY INSTRUCTIONS

ITEM NO : B8280 - 7
TACOMA TV STAND

STEP 7

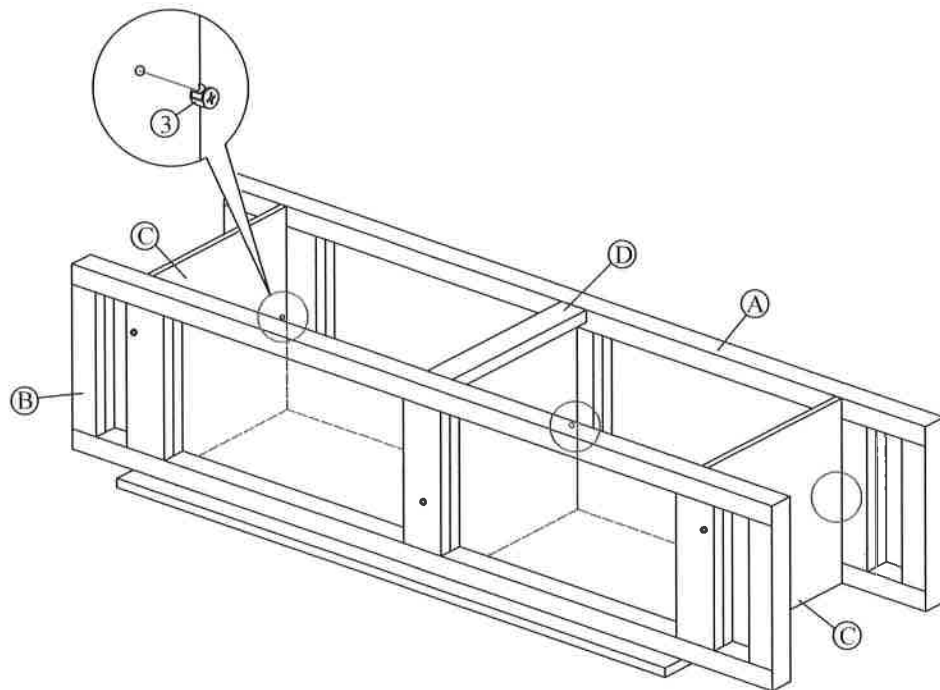

STEP 8

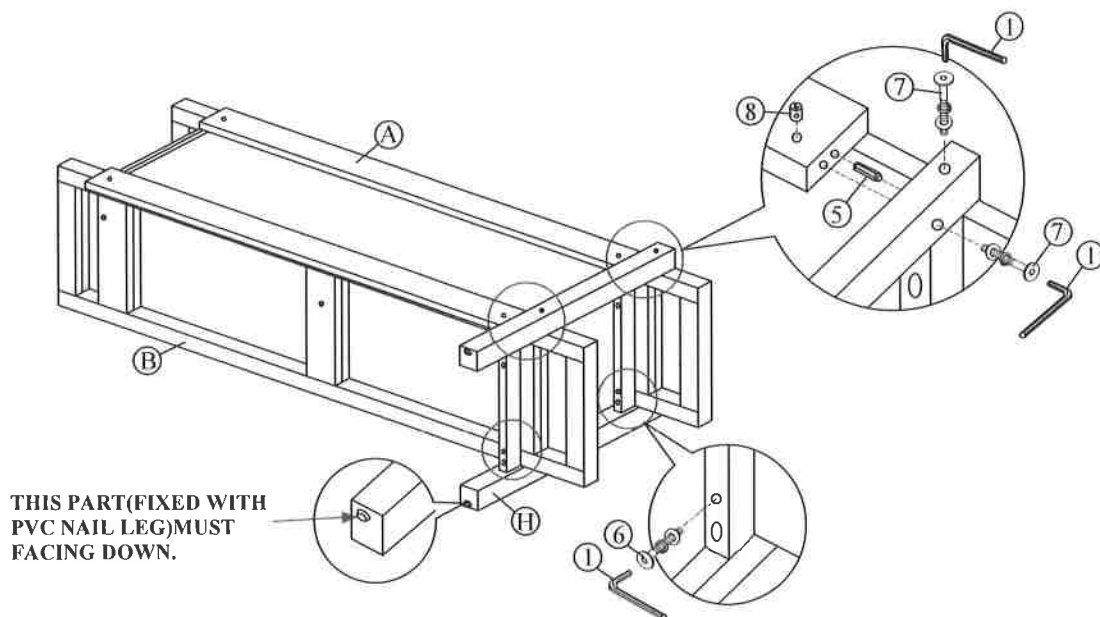

THE HARDWARE IS LOCATED IN THE PACKING ITEMS

NOTE : MUST TIGHTEN SCREWS PERIODICALLY. WITH USE SCREW MAY BECOME LOOSE.
CHECK TIGHTNESS OF ALL SCREW EVERY 6-8 WEEKS.

CLEANING INSTRUCTION

After assembly, clean & polish the completed parts if necessary with soft cloth and industrial recognized furniture polish

MADE IN MALAYSIA

ASSEMBLY INSTRUCTIONS

ITEM NO : B8280 - 7
TACOMA TV STAND

STEP 9

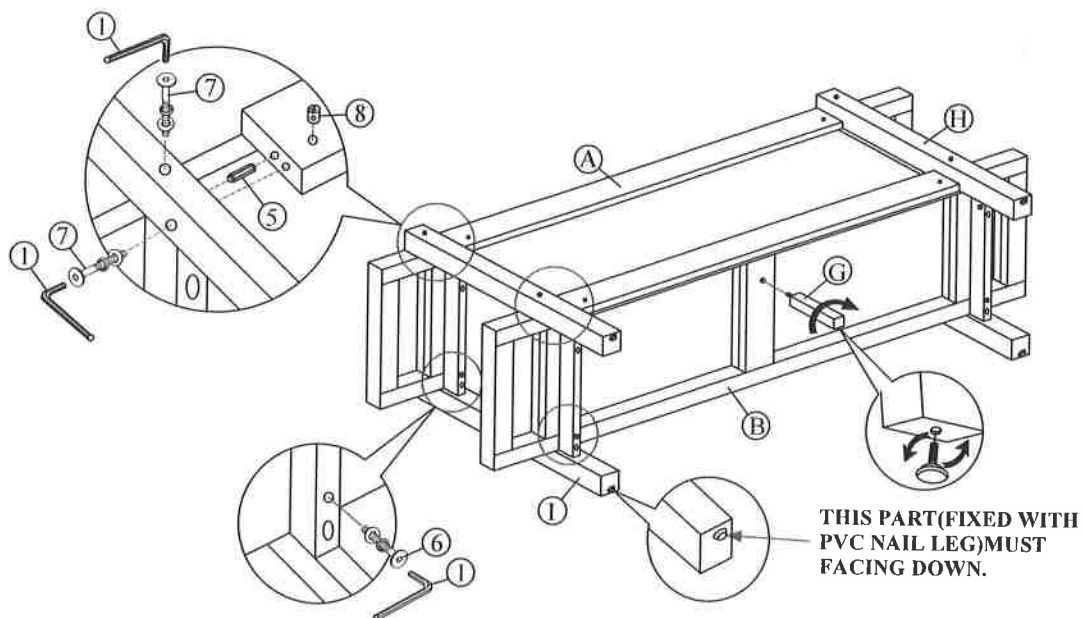

STEP 10

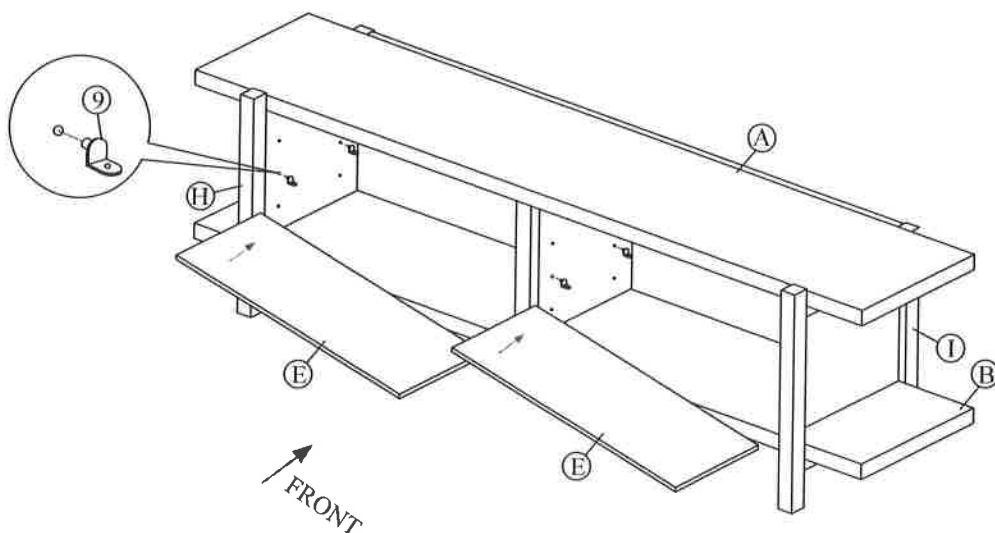

THE HARDWARE IS LOCATED IN THE PACKING ITEMS

NOTE : MUST TIGHTEN SCREWS PERIODICALLY. WITH USE SCREW MAY BECOME LOOSE.
CHECK TIGHTNESS OF ALL SCREW EVERY 6-8 WEEKS.

CLEANING INSTRUCTION

After assembly, clean & polish the completed parts if necessary with soft cloth and industrial recognized furniture polish

MADE IN MALAYSIA

