







Important safety instructions:

- Please carefully read all instructions before assembling.
- For your safety and ease, assembly by two or more adults is recommended.
- Keep instructions for future use.

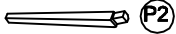
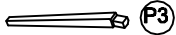



Pre-assembly:

- Do not discard any contents until after assembly is complete to avoid accidentally discarding small parts or hardware.
- Remove all parts and hardware from box along with any plastic protective packaging.

Parts List

Item	Description		QTY
P1	Chair Top		1
P2	Back Left Leg	 P2	1
P3	Back Right Leg	 P3	1
P4	Front Right Leg	 P4	1
P5	Front Left Leg	 P5	1
P6	Front Stretcher	 P6 W / metal kickplate	1
P7	Back Stretcher	 P7	1
P8	Left Side Stretcher	 P8	1
P9	Right Side Stretcher	 P9	1



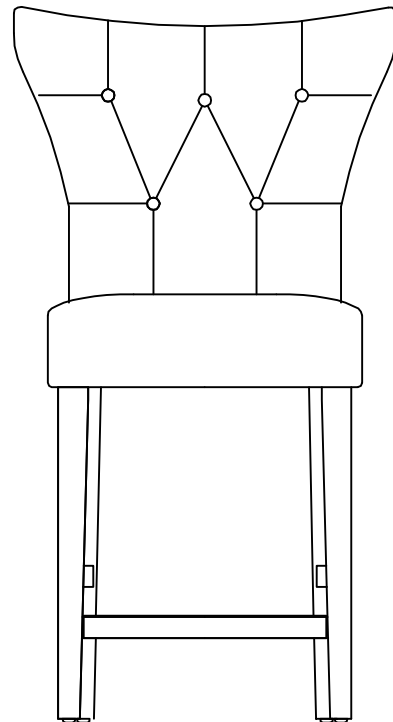

Hardware List

Item	Description		QTY
H1	Bolts Ø5/16"*2-1/4"L		8
H2	Lock Washers 5/16"		8
H3	Flat Washers 5/16"		8
H4	Allen Wrench 5/16"		1
H5	Screws #8*1-3/4"		8





Assembly Procedures:

Step 1. Assemble the stool on a flat, soft surface such as a carpet or cloth to prevent scratching the finish. Open the bottom covering. **Loosely** attach the back left leg (P2) to seat cushion (P1) following the label "P2" on the back left leg (P2) and seat cushion (P1) accordingly and using bolts (H1), lock washers (H2) and flat washers (H3) as shown below.

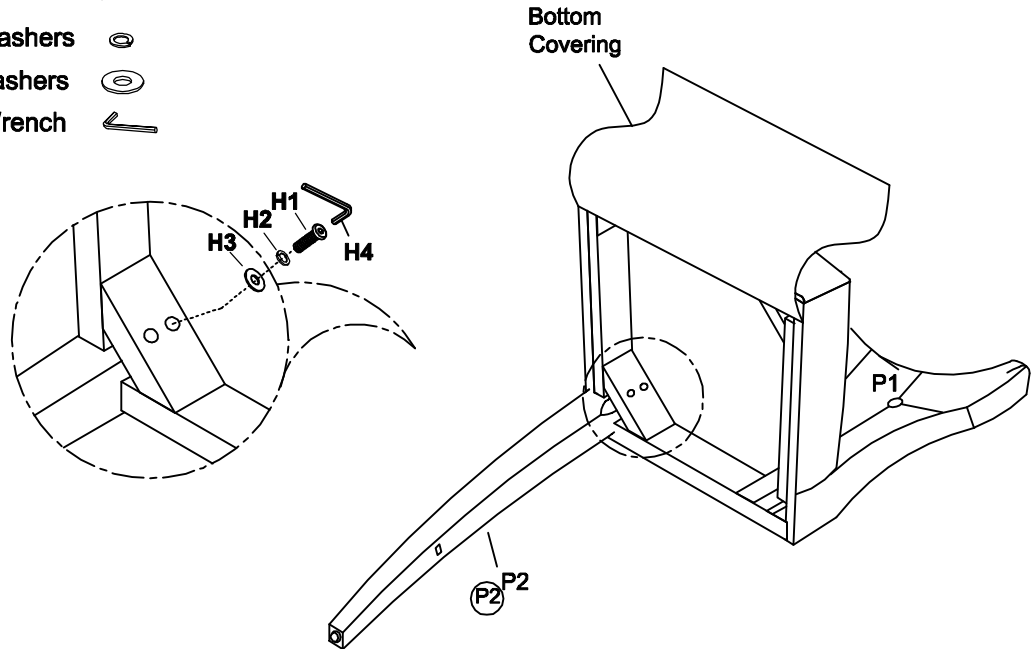
- (H1)x2 Bolts 
- (H2)x2 Lock Washers 
- (H3)x2 Flat Washers 
- (H4)x1 Allen Wrench 



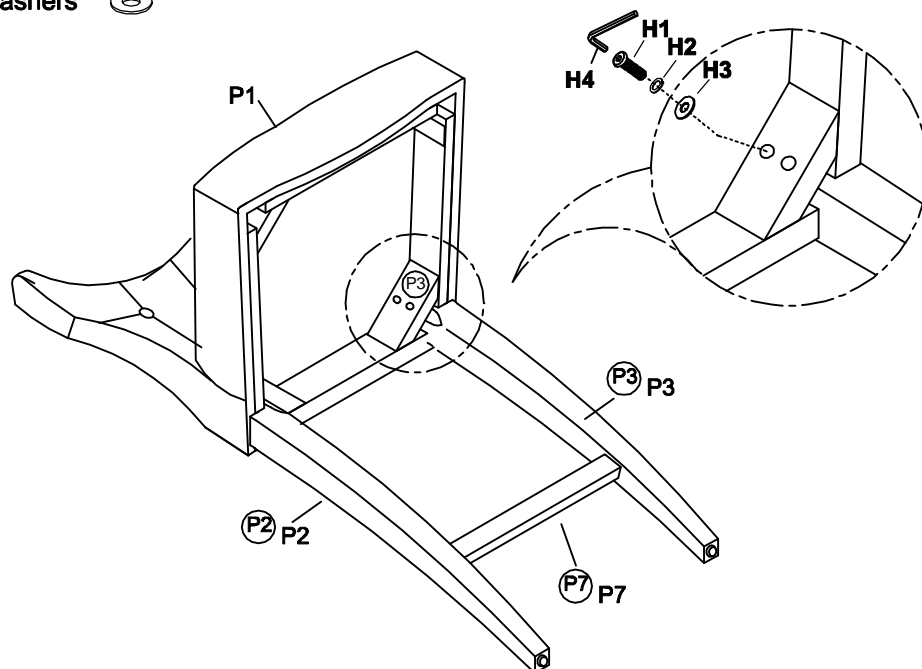

Step 2. Insert the back stretcher (P7) between two back legs (P2 & P3) following the labels "P2", "P3" and "P7" on each leg and the bottom of seat frame accordingly. **Loosely** attach the back right leg (P3) to the bottom of seat cushion (P1) using bolts (H1), lock washers (H2) and flat washers (H3) as shown below.

- (H1)x2 Bolts 
- (H2)x2 Lock Washers 
- (H3)x2 Flat Washers 





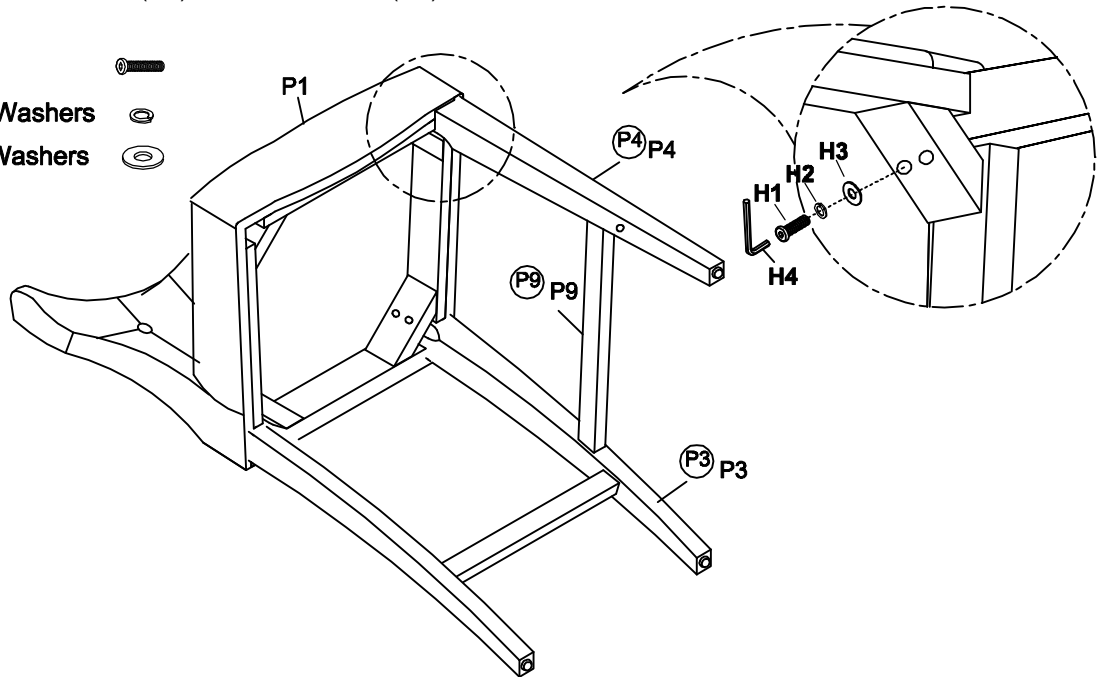

Step 3. Insert the right side stretcher (P9) between the back right leg (P3) and front right leg (P4) following the label "P9" and "P4" on each part accordingly. **Loosely** attach front right leg (P4) to the bottom of seat cushion (P1) using bolts (H1), lock washers (H2) and flat washers (H3) as shown below.

- (H1)x2 Bolts 
- (H2)x2 Lock Washers 
- (H3)x2 Flat Washers 



Step 4.

- 1) Insert front stretcher (P6) between front legs (P4,P5), and insert left stretcher (P8) between front left leg (P5) and the back left leg (P2) following "P6" and "P8" on each part accordingly, then **loosely** attach front right leg (P5) to the bottom of seat cushion (P1) using short bolt (H1), lock washer (H2) and flat washer (H3) as shown below.
- 2) Tighten screws (H5) through the stretchers (P6, P7, P8, P9) to each leg with screw driver (not provided).
- 3) Make sure the stool is level and securely tighten all bolts by Allen wrench (H4). Close the bottom covering on the bottom of seat cushion (P1).
- 4) Assembly is complete. **Failure to follow these instructions may cause the bolts to misalign during assembly.**

- (H1)x2 Bolts 
- (H2)x2 Lock Washers 
- (H3)x2 Flat Washers 
- (H5)x8 Screws 

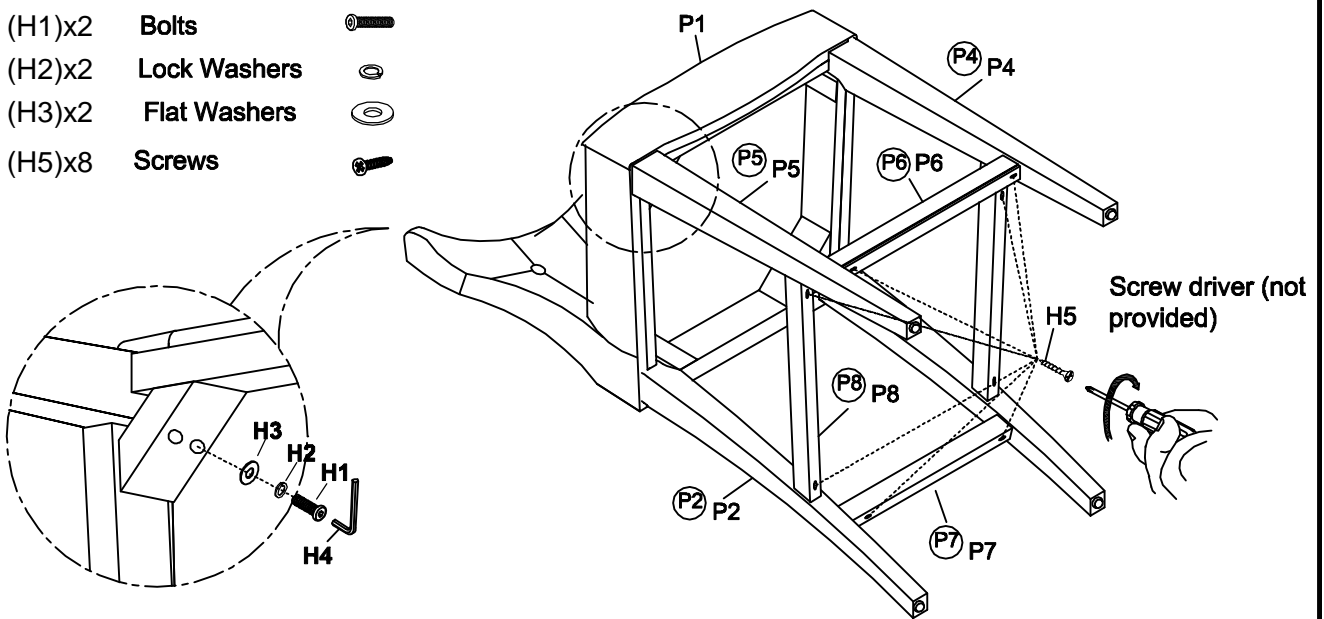

ADDITIONAL NOTE ABOUT SAFETY: BOLTS MAY LOOSEN DURING NORMAL EVERYDAY USE. THEY SHOULD BE PERIODICALLY INSPECTED AND RE-TIGHTENED TO PREVENT DAMAGE OR INJURY. ALWAYS CHECK TO BE SURE THAT ALL HARDWARE IS KEPT TIGHTENED.

Thank you for your purchase