

LIVING SPACES



ASSEMBLY INSTRUCTION



ITEM 305-P380260

Kara Wood Back Side Chair



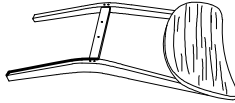

Thank you for purchasing this quality product. Be sure to check all packing material carefully for small hardware which may have come loose inside the carton during shipment. Identify and count all hardware and compare with the hardware list below.

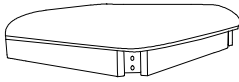
When placing furniture on non-carpeted flooring, HMI recommends the use of floor protection such as an area rug or furniture pads. Area rugs and padding not included with purchase.

PARTS LIST

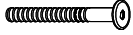
No.	Description	Sketch	Quantity
1	Wooden Chair Back		1pc
2	Front Leg		2pcs
3	Seat Cushion		1pc

HARDWARE LIST

No.	Description	Sketch	Quantity
A	JCBC Screw M6 x 35mm		2pcs
B	JCBC Screw M6 x 60mm		4pcs
C	JCBC Screw M6 x 80mm		4pcs
D	Spring Washer M6 x 12mm Ø		10pcs
E	Flat Washer M6 x 19mm Ø		10pcs
F	Allen Key M4 x 65mm		1pc

STEP 1

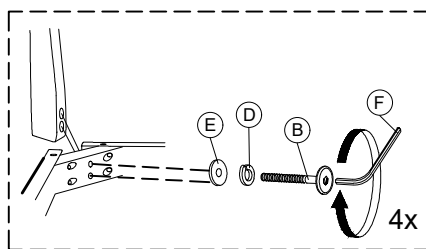

-Attach Front leg(2) to Seat Cushion(3),

Do not fully tighten at this moment.

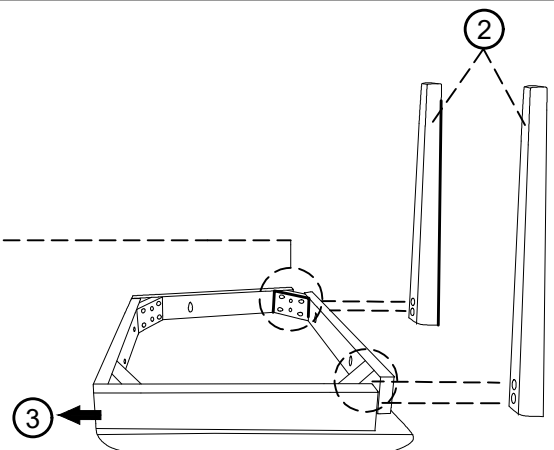

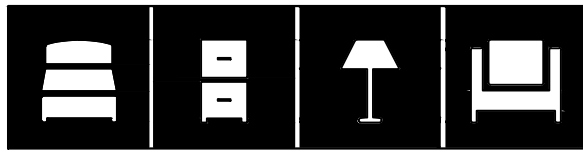

LIVING SPACES



STEP 2

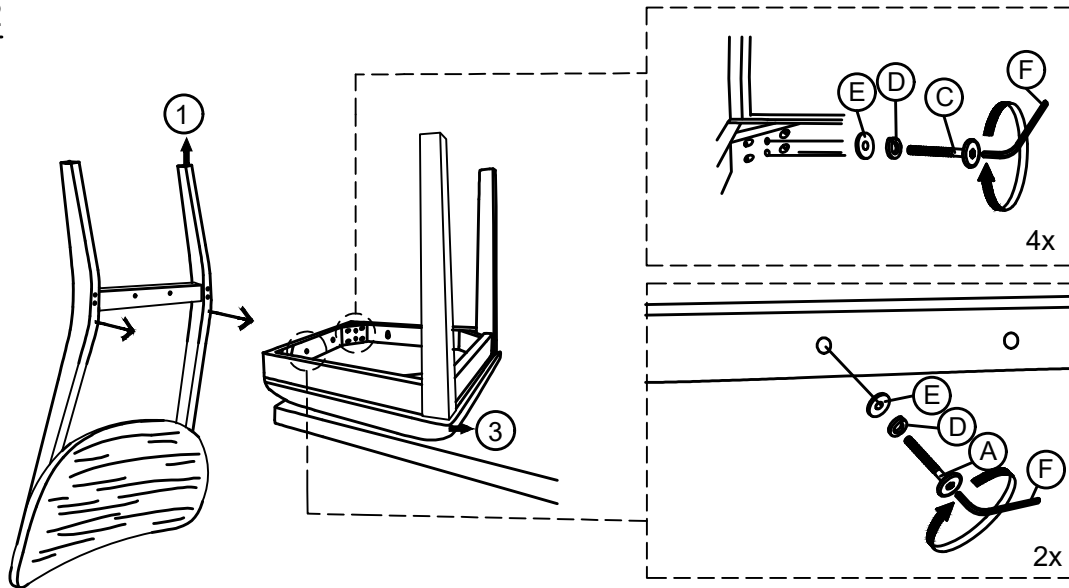

-Place Cushion Seat(3) on a clean flat surface
attach with Back Chair(1).

COMPLETE

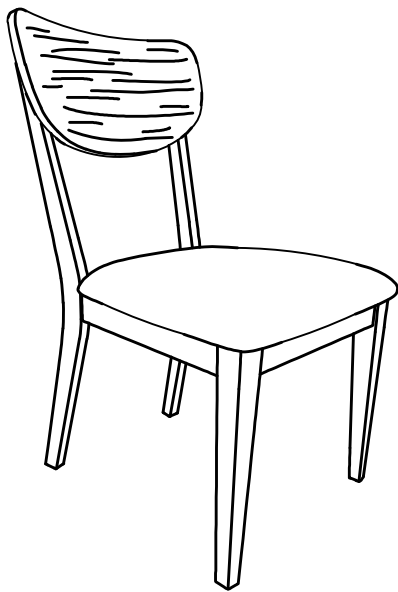

Turn the chair upright and place on level surface.

Adjust the front legs so that chair is level and does not wobble.

Tighten all the bolts and take care do not over tighten.

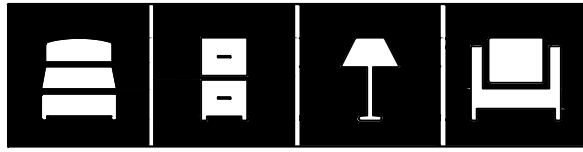

LIVING SPACES

REPLACEMENT PARTS

ITEM 305-P380260

Kara Wood Back Side Chair

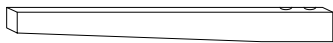

x2 R305-P380260-LEGF
Front Leg

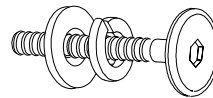

x1 R305-P380260-HWKIT
Hardware Kit

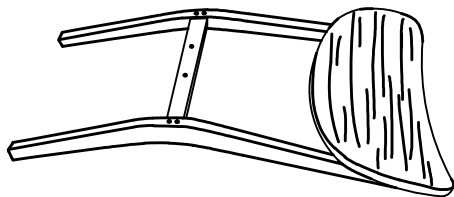
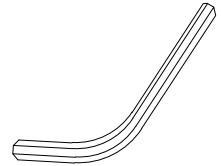

x1 R305-P380260-BACK



x1 R305-P380260-SEAT