

# ASSEMBLY INSTRUCTIONS



ITEM NO : B3350-Q-HB / B3350-Q-FB / B3350-KQ-RAIL  
TREVOR QUEEN BED

**BOX 1  
HEADBOARD**

ITEM	DRAWING	DESCRIPTION	QTY
A		HEADBOARD PANEL	1

**BOX 2  
FOOTBOARD AND SLATS**

ITEM	DRAWING	DESCRIPTION	QTY
B		FOOTBOARD PANEL	1
C		SLAT	5
D		SLAT SUPPORT	5

**BOX 3  
SIDE RAILS**

ITEM	DRAWING	DESCRIPTION	QTY
E		SIDE RAIL	2

**BOX 2  
HARDWARE LIST**

ITEM	DRAWING	DESCRIPTION	QTY
1		JCBC BOLT WITH SPRING WASHER AND FLAT WASHER (M8 x 25mm)	8
2		ALLEN KEY (M5)	1
3		SCREW P/H RATTAN (1/4) (8X1)	10

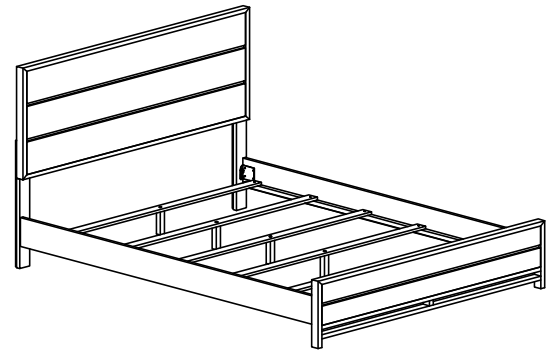

**COMPLETED QUEEN BED ASSEMBLY**

**STEP 1:** (Detail-A) Attaching the headboard panel (A) to the side rail (E) using the JCBC bolt (1).

**STEP 2:** (Detail-A) Inserting the slat support (D) into the side rail (E) and securing it with the screw P/H Rattan (3).

**STEP 3:** (Detail-A) Attaching the slat (C) to the slat support (D) using the screw P/H Rattan (3).

**Level Me on Uneven Floor:** A circular callout showing a leveling foot being adjusted on the side rail (E) to ensure the bed is level on an uneven floor.

**COMPLETED ASSEMBLY:** A sequence of four diagrams showing the final assembly of the headboard panel (A) to the side rail (E) using the JCBC bolt (1) and flat washer.

**THE HARDWARE IS LOCATED IN THE PACKING ITEMS**

NOTE : MUST TIGHTEN SCREWS PERIODICALLY. WITH USE SCREWS MAY BECOME LOOSE.  
CHECK TIGHTNESS OF ALL SCREWS EVERY 6-8 WEEKS.

**CLEANING INSTRUCTION**

After assembled, clean & polish the completed parts if necessary with soft cloth and industrial recognized furniture polish

**MADE IN MALAYSIA**

# ASSEMBLY INSTRUCTIONS



ITEM NO : B3350-Q-HB  
TREVOR QUEEN HEADBOARD

**BOX OF HEADBOARD**

ITEM	DRAWING	DESCRIPTION	QTY
A		HEADBOARD PANEL	1
B		RIGHT HEADBOARD LEG	1
C		LEFT HEADBOARD LEG	1

**BOX OF HEADBOARD  
HARDWARE LIST**

ITEM	DRAWING	DESCRIPTION	QTY
1		JCBC BOLT WITH SPRING WASHER AND FLAT WASHER (M6 x 40mm)	6
2		ALLEN KEY (M4)	1

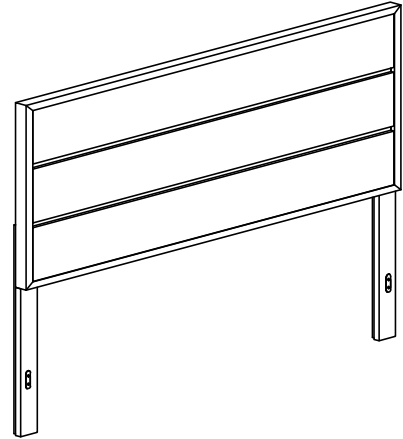

**COMPLETED QUEEN HEADBOARD ASSEMBLY**

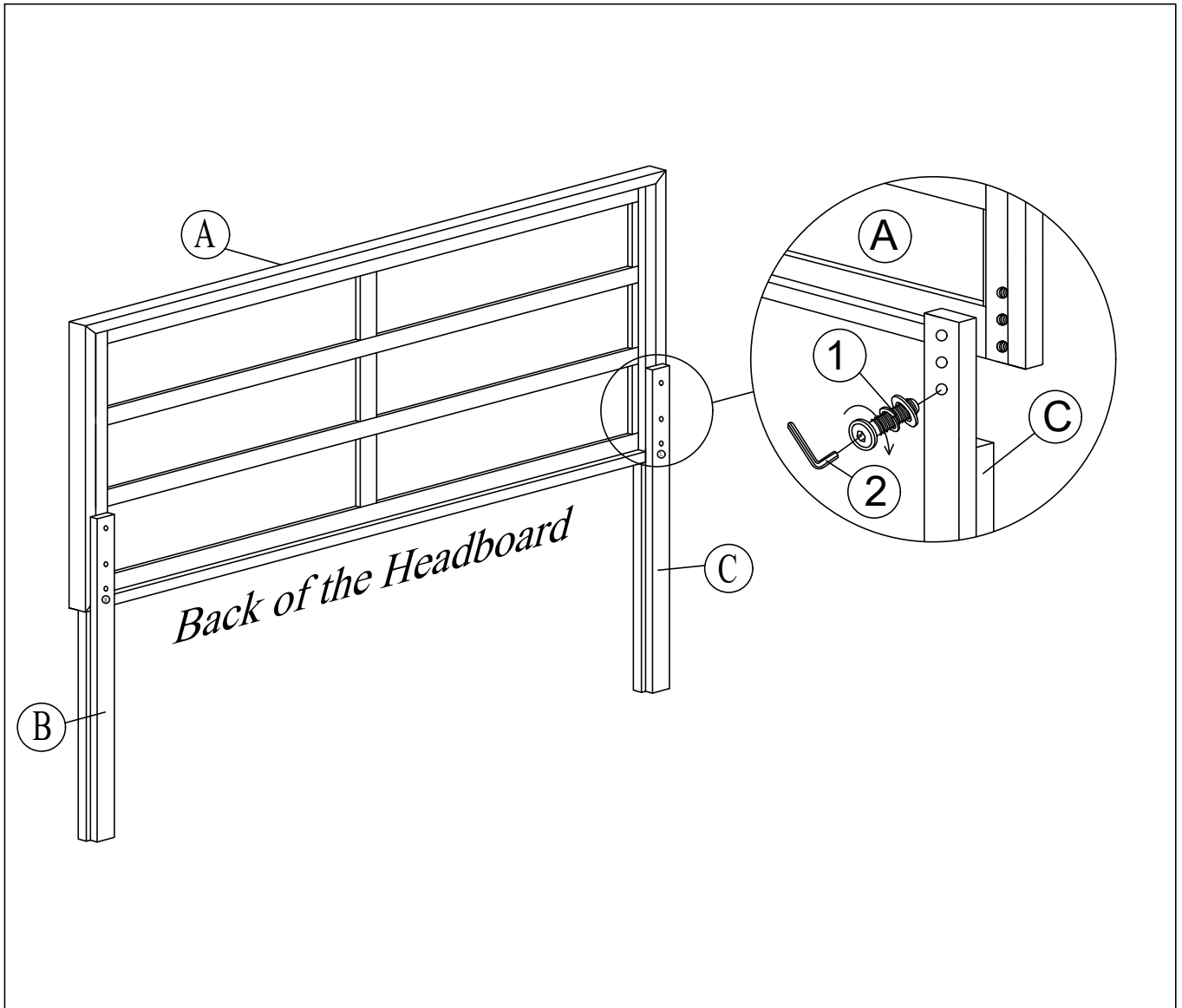

**THE HARDWARE IS LOCATED IN THE PACKING ITEMS**

NOTE : MUST TIGHTEN SCREWS PERIODICALLY. WITH USE SCREWS MAY BECOME LOOSE.  
CHECK TIGHTNESS OF ALL SCREWS EVERY 6-8 WEEKS.

**CLEANING INSTRUCTION**

After assembled, clean & polish the completed parts if necessary with soft cloth and industrial recognized furniture polish

**MADE IN MALAYSIA**